

Plug electrical connection  
M2 15x15

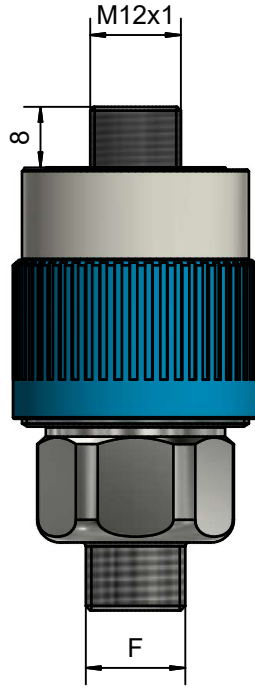

Plug electrical connection  
M3 30x30

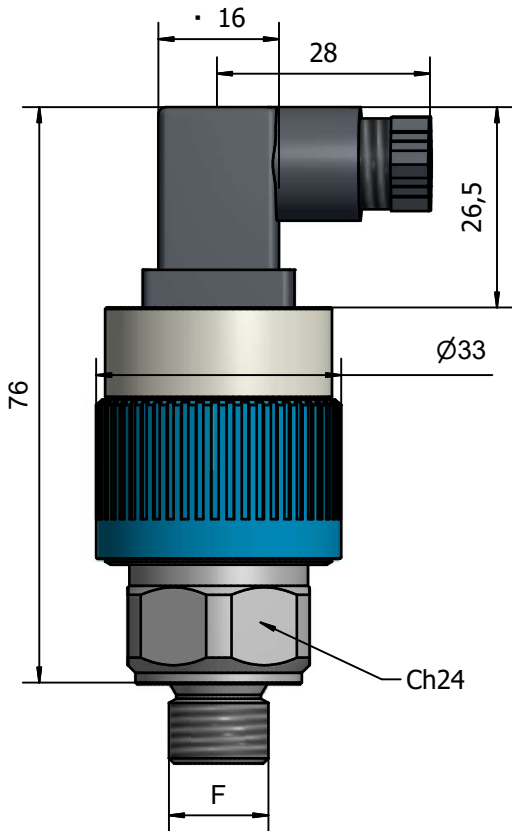
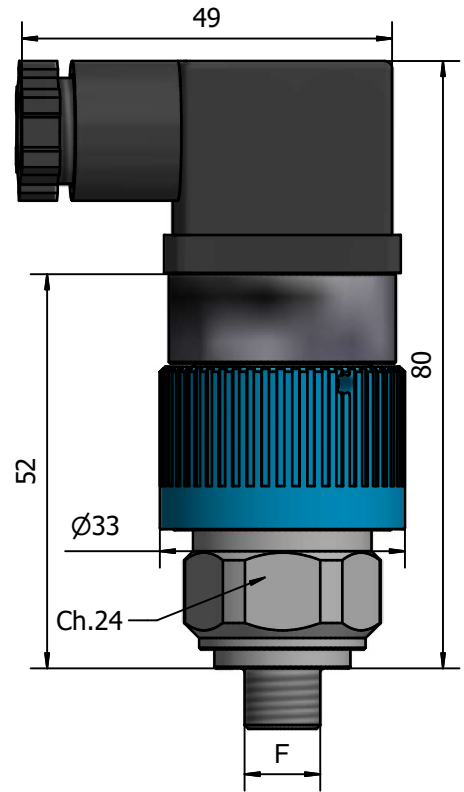

### TECHNICAL FEATURES F7

- PRESSURE RANGE: FROM 1BAR TO 400BAR
- BODY: BRASS, ZINC-PLATE CARBON STEEL OR A316 STAINLESS STEEL
- CONNECTION THREADED: SEE THE LIST
- WORKING TEMPERATURE: FROM -25°C TO 85°C
- SWITCHING FREQUENCY: 90 CYCLES / MINUTE
- SWITCHING ACCURACY: FROM 0,5 TO 4BAR
- FIXED HYSTERESIS VALUE: +/- 10% OF THE END OF SCALE TO 20°C  
10% OF THE END OF SCALE FOR MEMBRANE EXECUTION
- WEIGHT: 0.05 kg
- MECHANICAL LIFE: 10^6 CYCLES AT 70BAR AT 20°C

### ELECTRICAL FEATURES

- MAXIMUM LOAD: 3A AT 24 VOLT DC
- ELECTRIC CONNECTION: ACCORDING TO DIN43650 M3 TYPE
- ELECTRIC PROTECTION: IN ACCORDING TO DIN40050:IP65
- ELECTRICS CONTACTS: IN EXCHANGE 1>2 NC AND 1>3 NO

Thread available	F
0	1/8" BSP
1	1/4" BSP
2	1/8" BSPT
3	M10x1
4	1/8" NPT
5	1/4" NPT
6	1/4" BSPT

ALL DIMENSION ARE IN MILLIMETER EXCEPT WHERE OTHERWISE NOTED 	Projection:ISO128	Date	Name:	DESCRIPTION:  Adjustable pressure switch F7  DRAWING No/FILE NAME  F7-Datasheet	SCALE:  1:1  SHEET 1 of 1
		11/09/2017	ec		
		11/09/2017	aa		
	APPROVED:				
	FOX S.r.l. Via Romagna 6 20090 Opera (MI) ITALY 				